

Technical Documentation of the PAF Receiver 0.7 - 1.8 GHz (P190)

Type	PHEMETS LNA, Air and Heat Sink cooling system
Channel	188
Tsys	300K
RF Frequency Range	700-1800 MHz
Band Width RF Filter	BPF LOW(700-1200MHZ):3dB
→	BPF MID(840-1450MHz)
→	BPF HIGH(1400-1800 MHz)
→	LPF(700MHz

Block Diagram

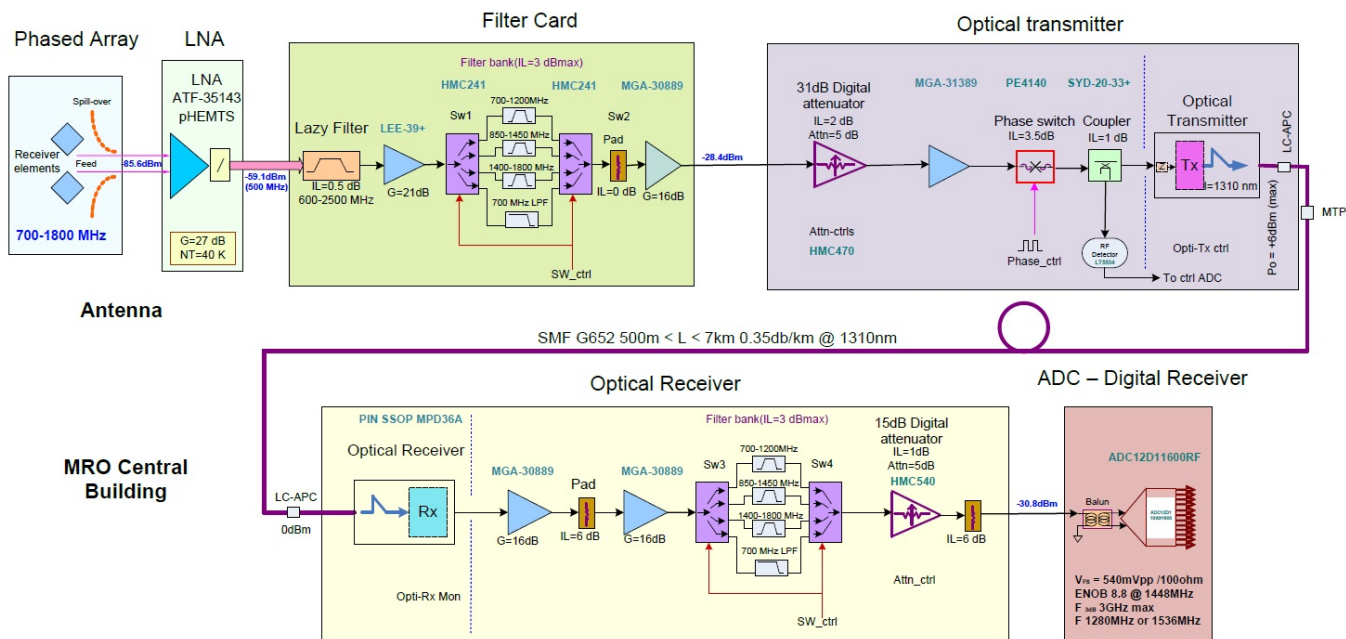

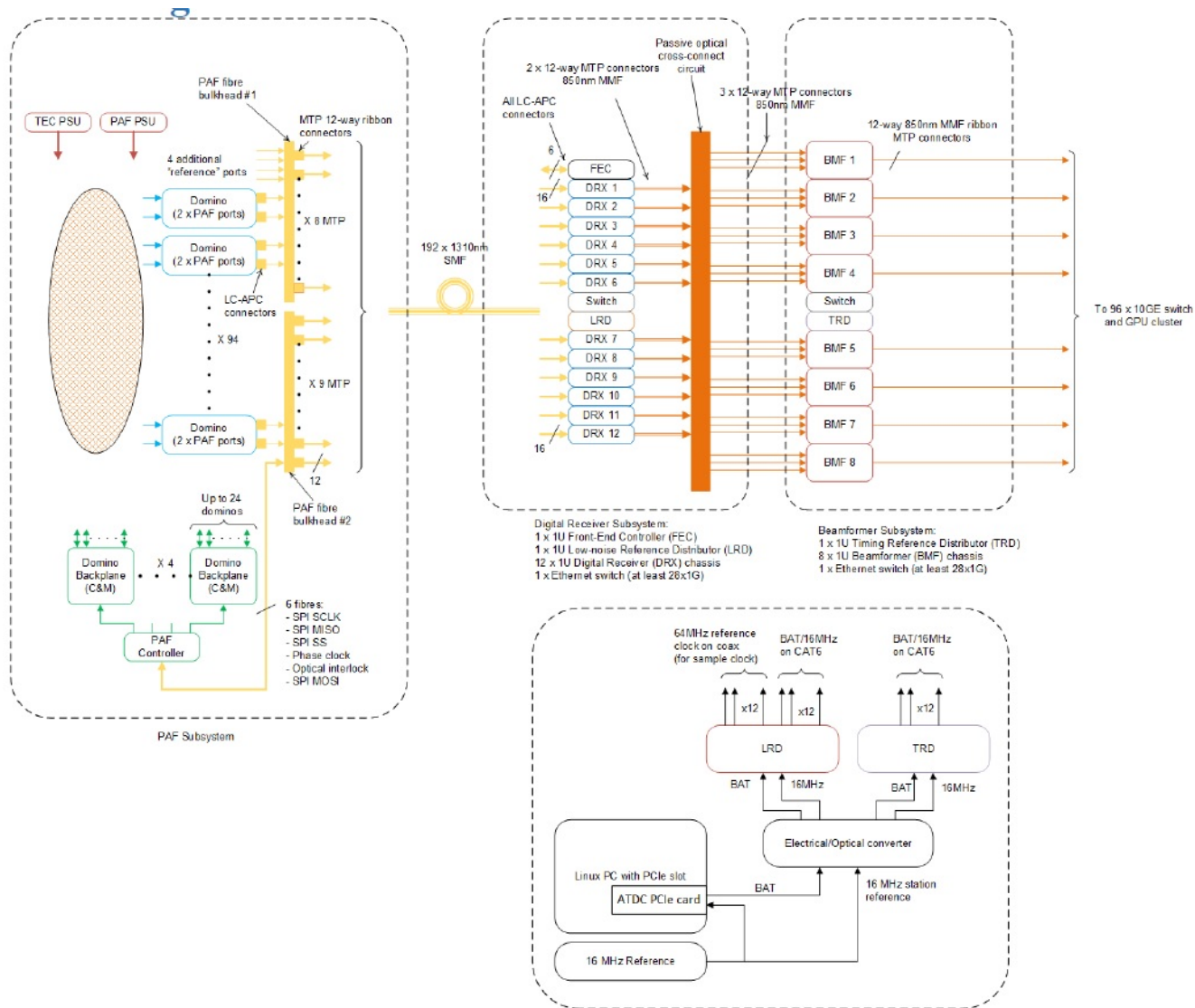

Charts

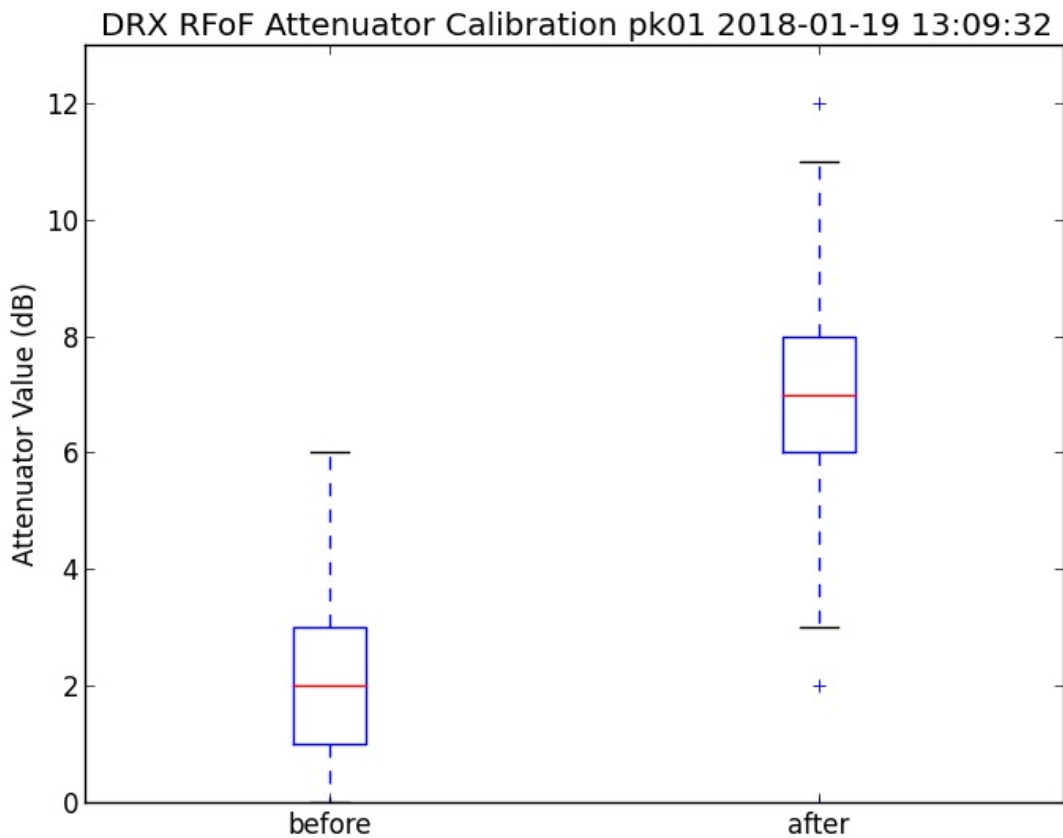
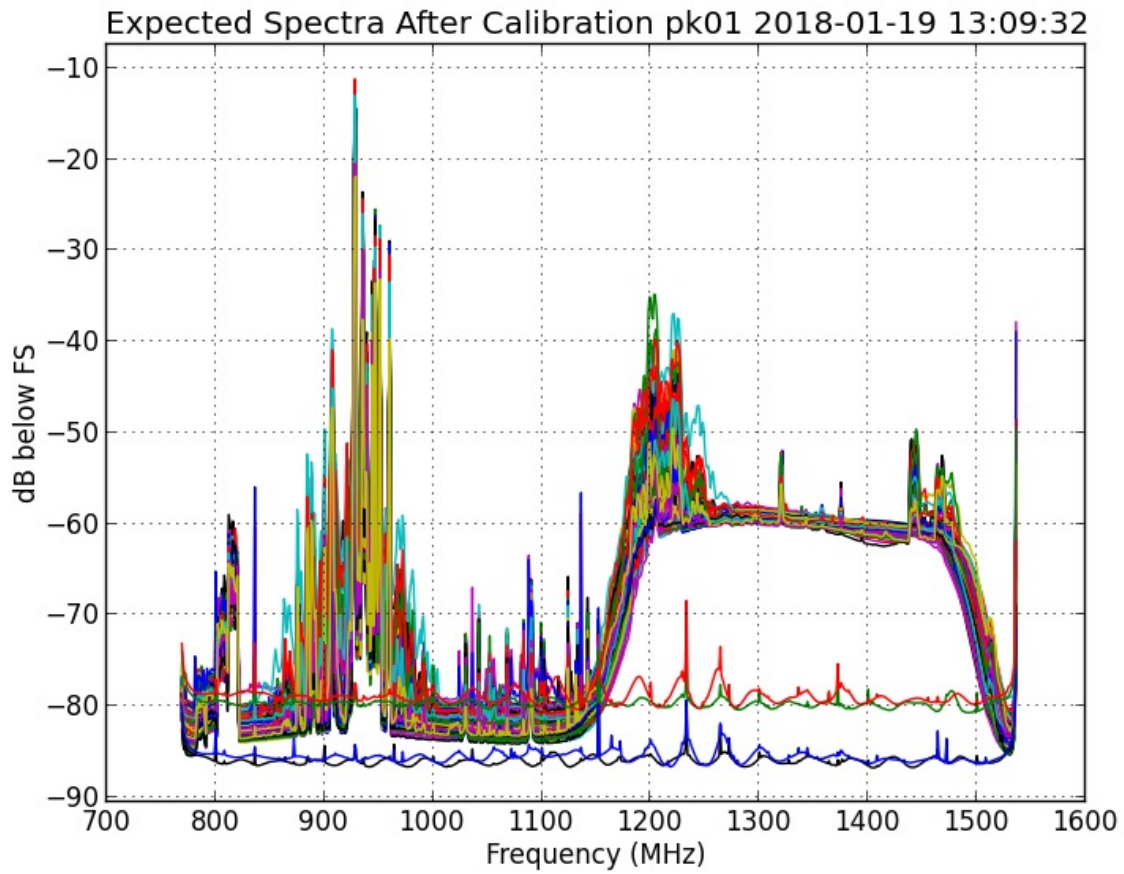

Last update: 2019/12/13 12:02 electronics:rx:techinfo:documentation_p190mm https://eff100mwiki.mpifr-bonn.mpg.de/doku.php?id=electronics:rx:techinfo:documentation_p190mm

PAF Controller Supply Voltage Measurement (29.08.2018) Z.Kpaf_controller_supply_voltage.pdf

From:

<https://eff100mwiki.mpifr-bonn.mpg.de/> - **Effelsberg 100m Teleskop**

Permanent link:

https://eff100mwiki.mpifr-bonn.mpg.de/doku.php?id=electronics:rx:techinfo:documentation_p190mm 

Last update: **2019/12/13 12:02**