

10mm Primary Focus Cabin Receiver (26.5-38.7 GHz) System Block Diagram

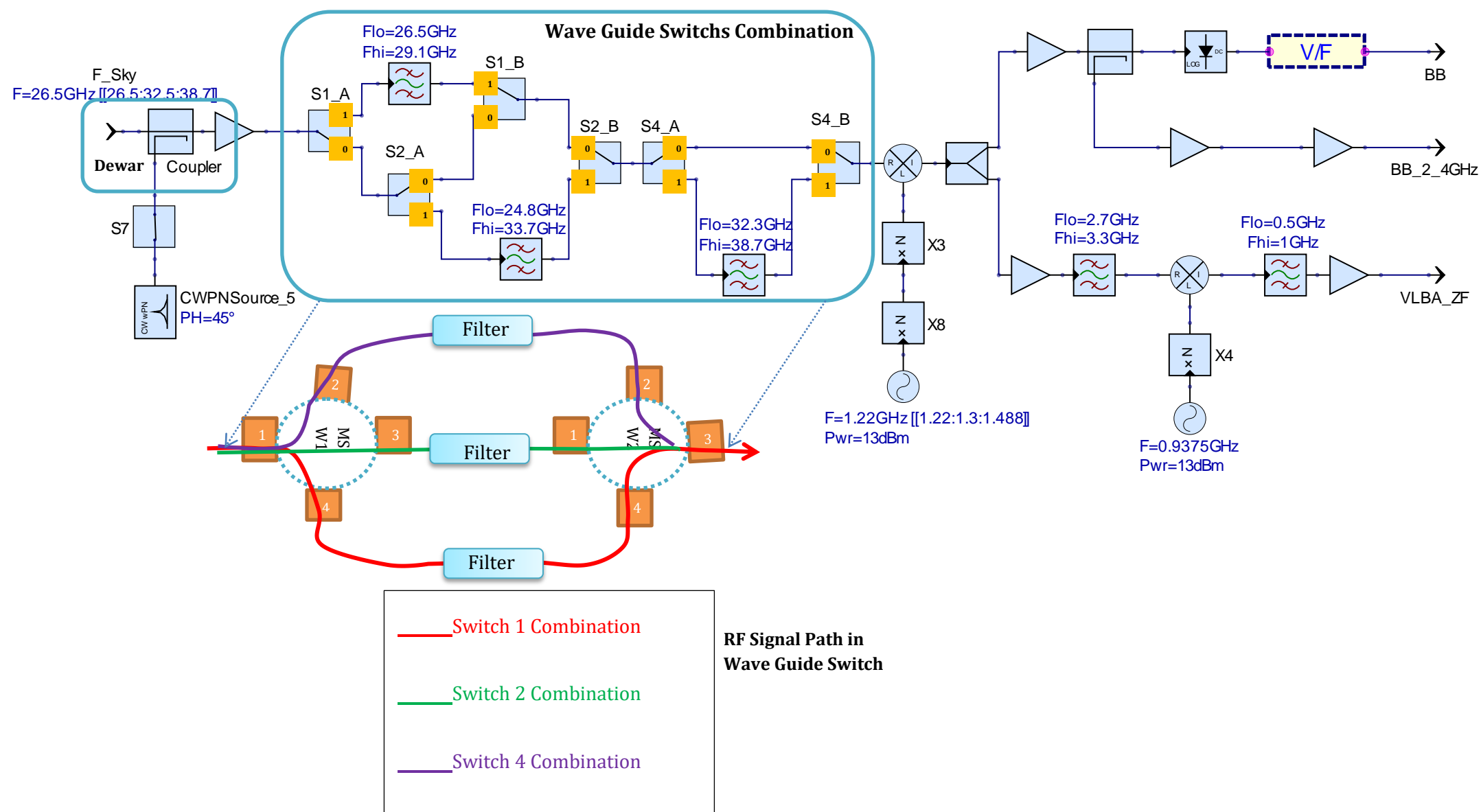

Wave Guide Switch Name	S1		S2		S4		Band Selection	
Wave Guide Switch Combination	S1_A	S1_B	S2_A	S2_B	S4_A	S4_B	Lower Side Band	Upper Side Band
Switch State	0		0		0		-	-
					1		-	Upper Side Band Filter is Selected (32.3-38.7 GHz)
					0	Lower Side Band Filter is Selected (24.8-33.7 GHz)	-	
					1	-	-	
Switch State	1		0		0		Lower Side Filter is Selected (26.4-29.1 GHz)	-
			1	1	-	-		

Switch S7 State S7 = 0 ; Noise Source Calibration is not selected ;S7=1; Noise source Calibration is selected

IGUI	Switch1	Switch2	Switch3	Switch4	Selected Filter	Band	RF in GHz	ULO1 in GHz	ULO2 in GHz
-	0	0	0	0	-	-	-	-	-
1	1	0	0	0	Filter1(26.4-29.1 GHz)	Lower Side Band	26.5-29.1	1.299-1.338	0.9357
2	0	1	0	0	Filter2(24.8-33.7 GHz)	Lower Side Band	28.5-32.4	1.313-1.488	0.9357
3	0	0	1	0	-	-	-	-	-
4	0	0	0	1	Filter3(32.3-38.7 GHz)	Upper side Band	32.3-38.7	1.220-1.488	0.9357

Switch 3 combination is not implemented.

10mm Primary focus cabin receiver (26.5-38.7 GHz)

This system is equipped with 3 RF-Filters to suppress mirror frequency reception. During observation, the filter and ULO settings have to be selected according to the observation frequency (see block diagram). In March 2007 the LNA was replaced by an InP-HEMT MMIC-amplifier designed for the 9mm receiver. Therefore the noise figure at low frequencies is not ideal. This system is part of the Primary Focus Multi Frequency Box #1 (PM 1).